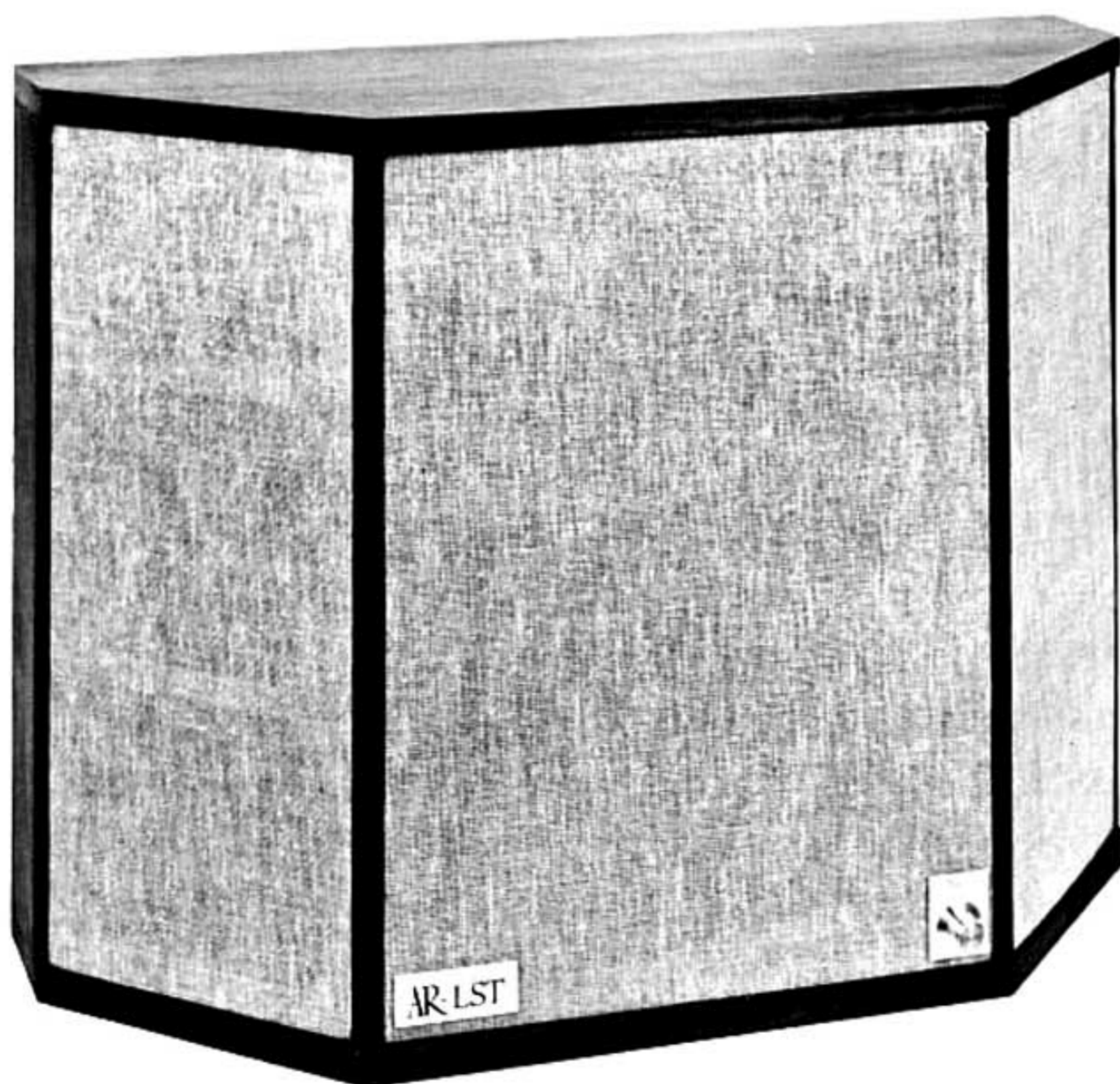


**HiFi ENGINE®**

For more Hi-Fi manuals and set-up information  
please visit [www.hifiengine.com](http://www.hifiengine.com)

AR *Laboratory  
Standard  
Transducer*



**Acoustic Research, Inc.**, 24 Thorndike Street, Cambridge, Massachusetts 02141

**Acoustic Research International n.v.**, Radiumweg 7, Amersfoort, Holland



## AR LABORATORY STANDARD TRANSDUCER

The AR Laboratory Standard Transducer is designed for those laboratory and commercial applications that require conveniently repeatable, accurately known spectral energy profiles, including one flat profile extending from 30 Hz to 20 kHz.

The AR-LST uses a 12-inch acoustic suspension woofer, four 1½-inch mid-range hemispherical radiators, and four ¾-inch hemispherical tweeters. The individual speakers are identical with those of an AR-3a system. Crossover frequencies are 575 and 5,000 Hz.

Four mid-range speakers and four tweeters are included in the AR-LST to provide increased power-handling ability. Each of these combinations is wired in series/parallel.

The AR-LST contains an autotransformer with taps at 1-db increments from 0 to -6 db. Each of the speakers is connected (through its crossover filter) to one pole of a 3-pole, 6-position selector switch, which is fed by the autotransformer taps, so that the relative output levels can be adjusted as desired. A large capacitor in series with the autotransformer prevents excessive amplifier loading at subaudible frequencies where the transformer's inductive reactance decreases.

Switch position No. 1 provides acoustic power response that rises slightly as frequency increases; the woofer output is 2 db lower than that of the tweeter. Position No. 2 is the flat energy setting. Positions 3 through 6 provide progressively greater slopes in energy response, with the level of low-frequency output increasing, relative to high-frequency output, by 2 db for each higher numbered switch setting. In positions 5 and 6 the balance of the AR-LST is approximately the same as that of an AR-3a with its level controls in the suggested "normal" settings.

Output level of the AR-LST mid-range units is held relatively constant for all of the six balance switch positions so that the overall impression of loudness does not change substantially as the switch position is changed.



Figure 1 shows typical  $\frac{1}{3}$ -octave energy-output curves for each of the switch positions, from 500 Hz through 20 kHz. Below 500 Hz the energy output is influenced by the acoustic environment; the woofer output into a  $2\pi$  steradian anechoic environment is shown in Figure 3. Because in this frequency range the system is completely nondirectional, the anechoic curve can be used to extend Figure 1 below 500 Hz when the AR-LST is placed with its back against the middle of a wall. The only differences will be those produced by variations in loading imposed by room reflections. Low-frequency output will be increased above that shown if the cabinet is placed in a corner; it will be decreased if the system is not close to a wall.

Figure 2 shows the impedance-*vs.*-frequency characteristics of the AR-LST for each of the six switch positions. Figure 3 shows the anechoic response of the AR-LST's individual drivers.

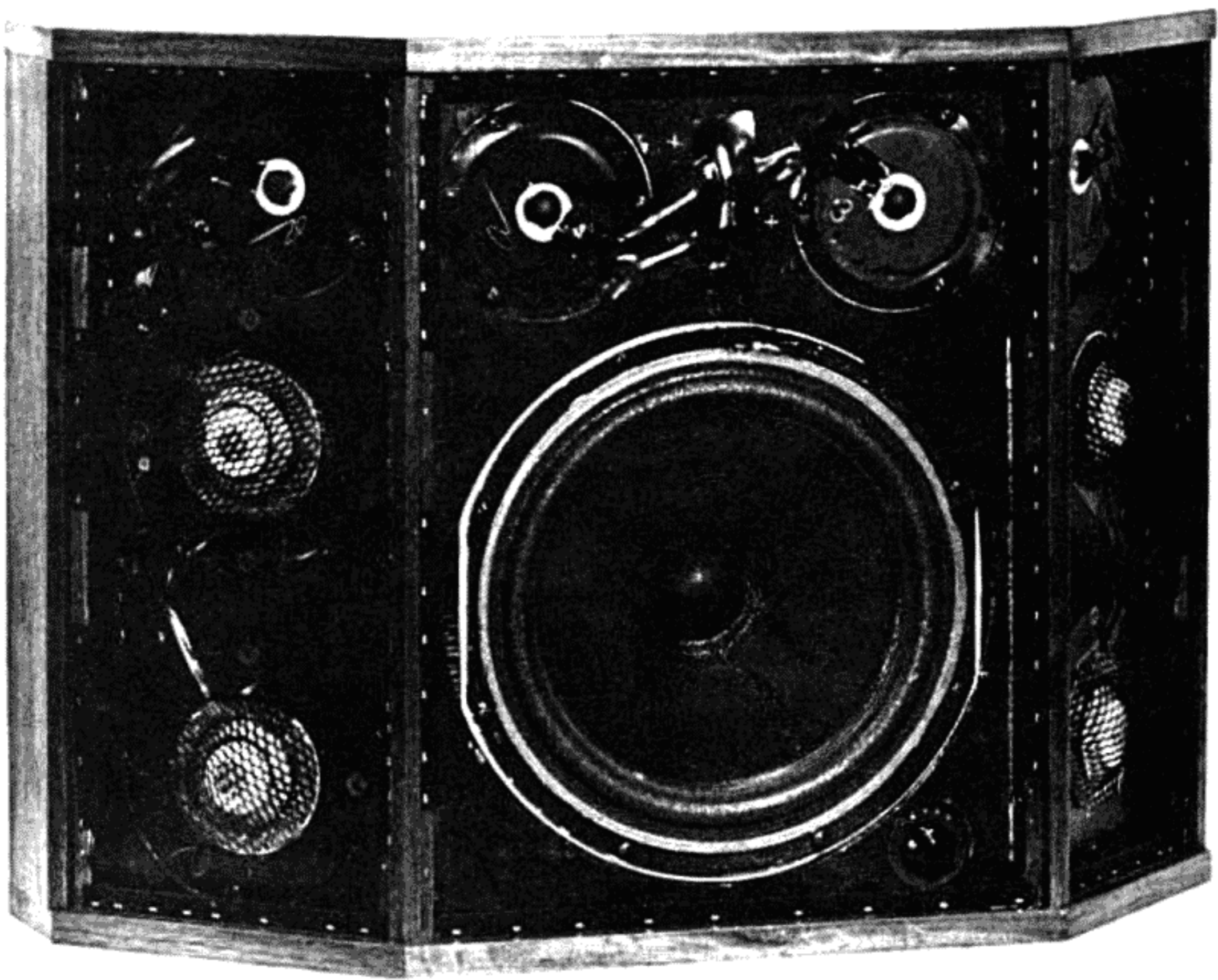
Figure 4 shows the low-frequency distortion characteristics of the AR-LST.

Figure 5 is a schematic diagram of the AR-LST crossover network/switching circuit.

Because the system impedance is increased by the autotransformer at middle frequencies relative to an AR-3a, the *apparent* efficiency of the AR-LST is lower if both systems are connected alternately to the same amplifier output terminals. Actually there is no difference in real efficiency, but in order to get the same amount of audio power into an AR-LST at middle frequencies the voltage gain must be greater and the preamplifier volume control setting will have to be increased.

The amount of high-frequency power handled by the tweeters in an AR-LST, when its balance switch is set at low numbers, is substantially greater than for an AR-3a tweeter if the systems are played at the same loudness. Even though the total high-frequency power is divided among four tweeter units, it is necessary to exercise care to prevent excessive high-frequency energy output.

**WARNING:** A fuse block and fuses are provided with the AR-LST. Under no circumstances should the fuse terminals be bypassed. No fuse other than FNM 2 should be used with this system. Replacement or repairs of speakers in the AR-LST system damaged by *excessive power input* are not covered by the guarantee.



### Specifications

Sensitivity: 89.5 db SPL average,  $\pm 1$  db, with back against rigid wall.

Efficiency: 0.8% average,  $2\pi$  radiation angle,  $\pm 1$  db.

Impedance: Depends on switch position; see Figure 2.

Frequency response,  $\pm 2$  db:

A. Total acoustic power output *vs.* frequency above 500 Hz, Figure 1.  
Below 500 Hz, woofer anechoic curve in Figure 3 applies for  $2\pi$  radiation angle.

B. Anechoic response shown in curves for individual speakers, Figure 3.

Power-handling ability with FNM 2 fuse: 180 watts for 10 seconds; 64 watts for 30 seconds; 23 watts long-term average. Based on current into assumed nominal impedance of 4 ohms.

Distortion: See Figure 4.

Speaker complement: 12" woofer, four 1½" mid-range hemispherical radiators, four ¾" hemispherical tweeters.

Phasing: Positive voltage applied to input terminal No. 2 causes woofer diaphragm to move forward (out of cabinet).

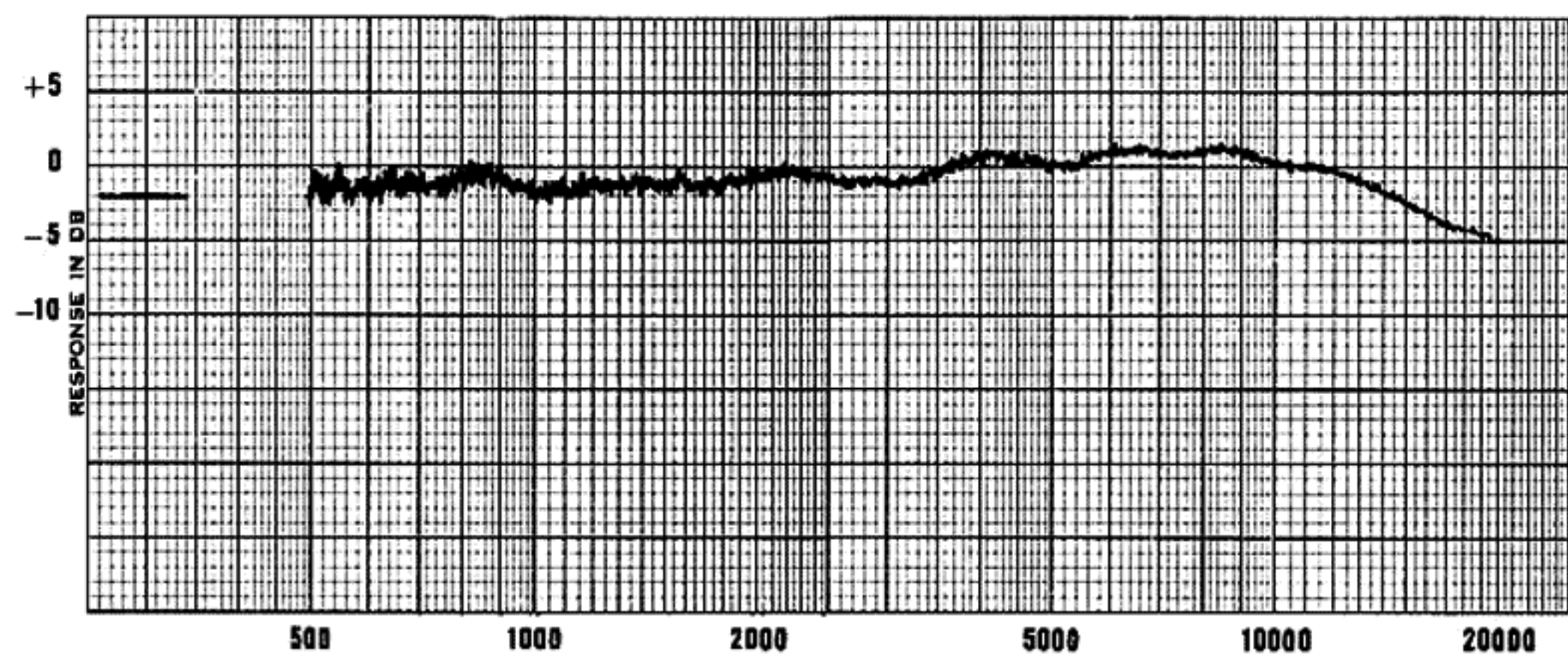
Cabinet size: 27¼" wide by 20" high by 9¾" deep, overall: 68.9 by 50.8 by 24.8 cm.

Weight: 90 pounds: 40.5 kg.

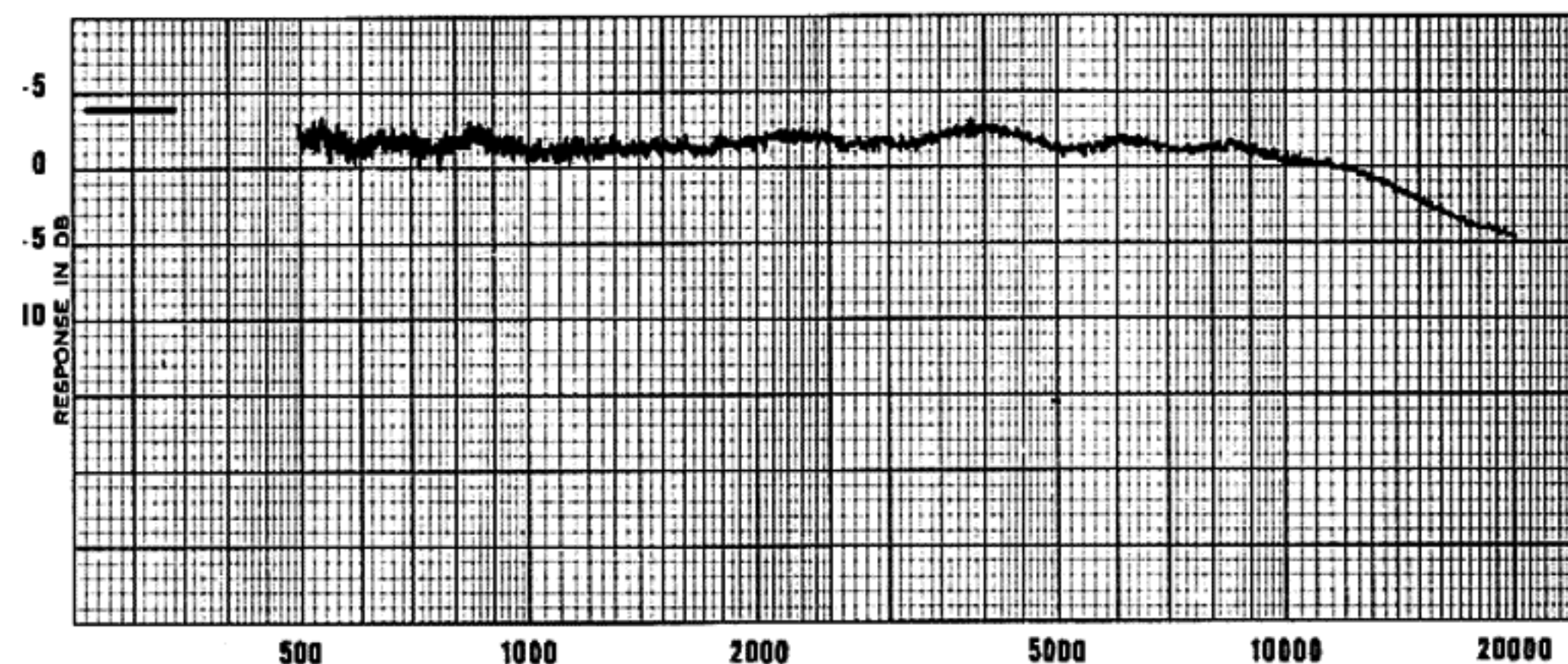


**Figure 1: AR-LST Spectral Energy Profiles**

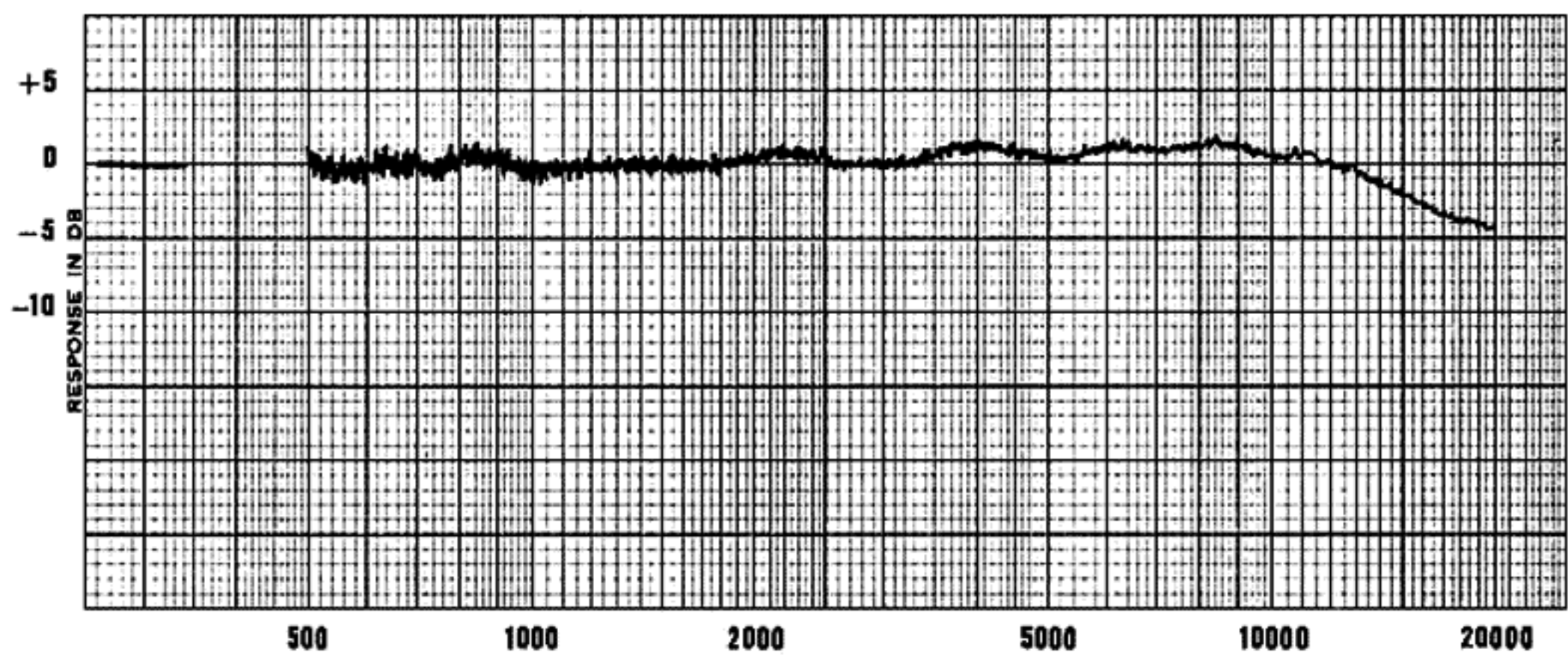
Horizontal line at left  
indicates relative woofer level



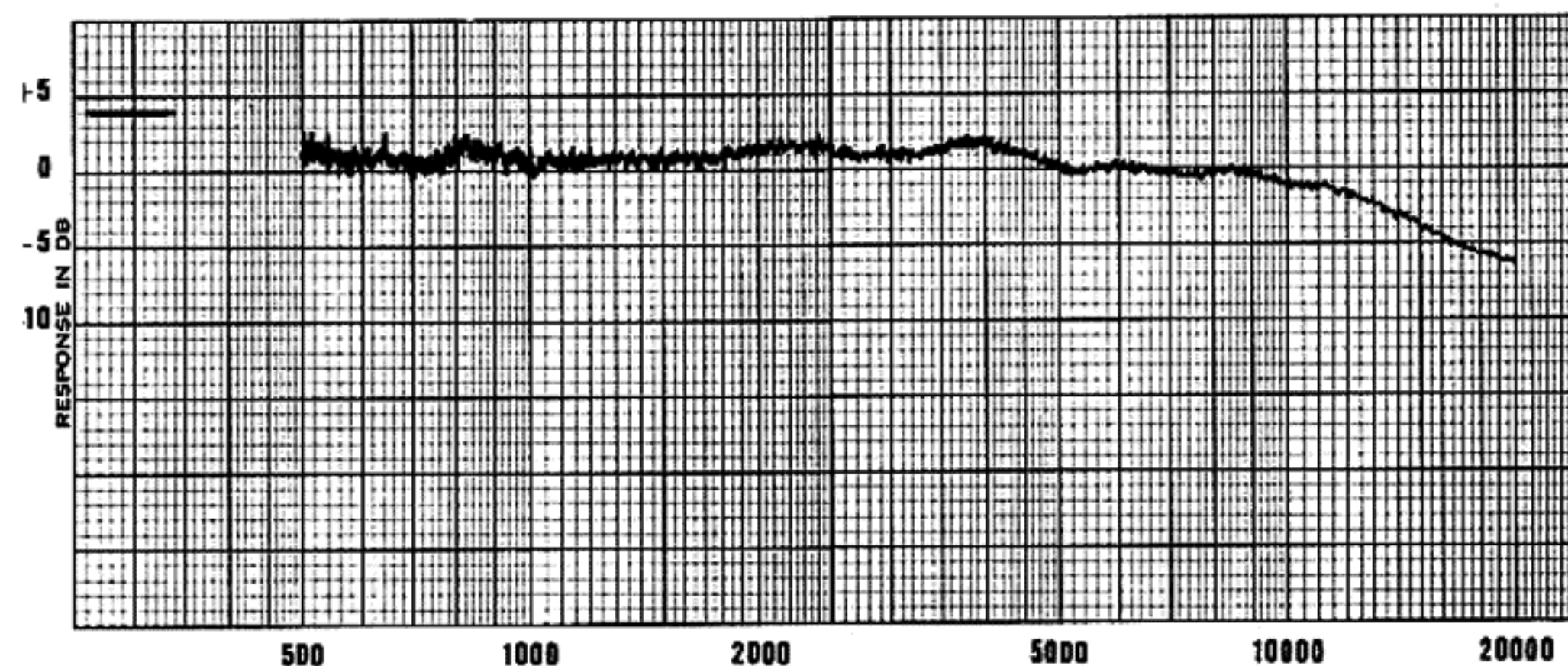
**Switch Position 1**



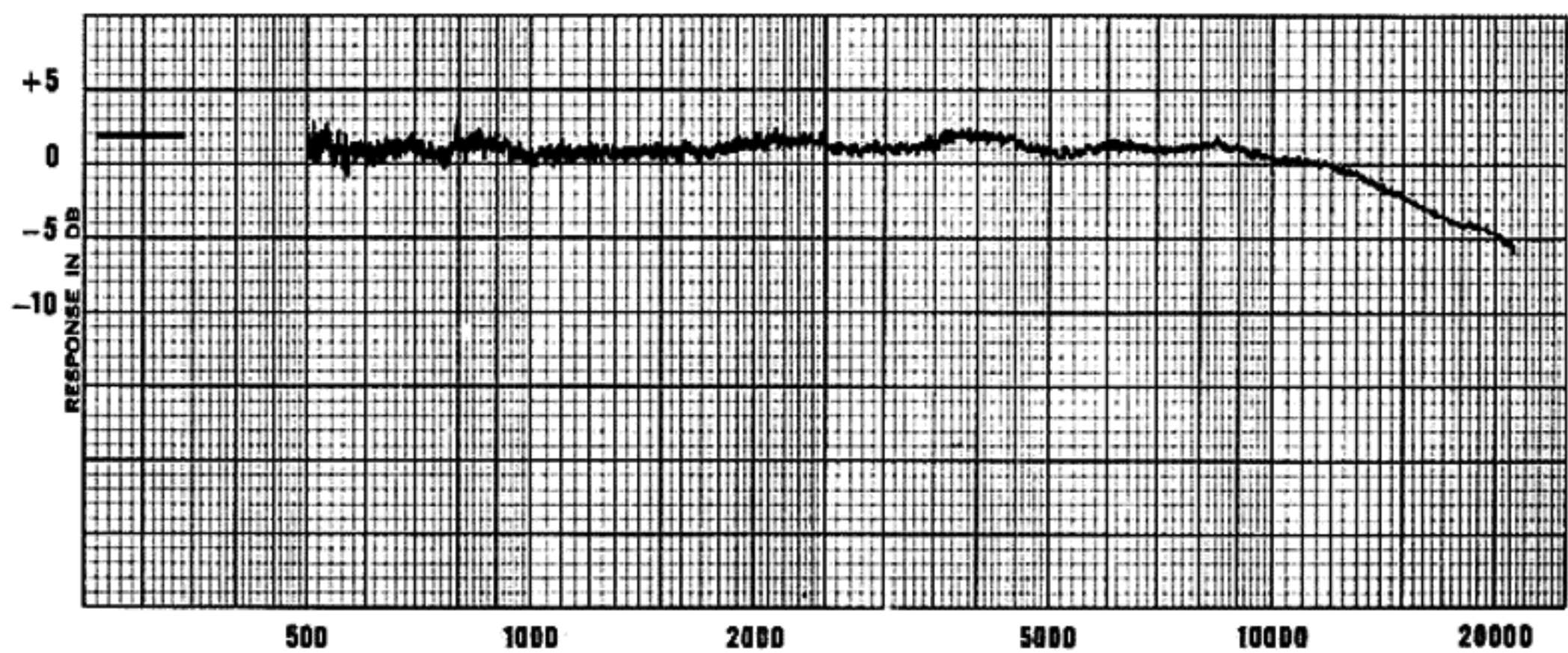
**Switch Position 4**



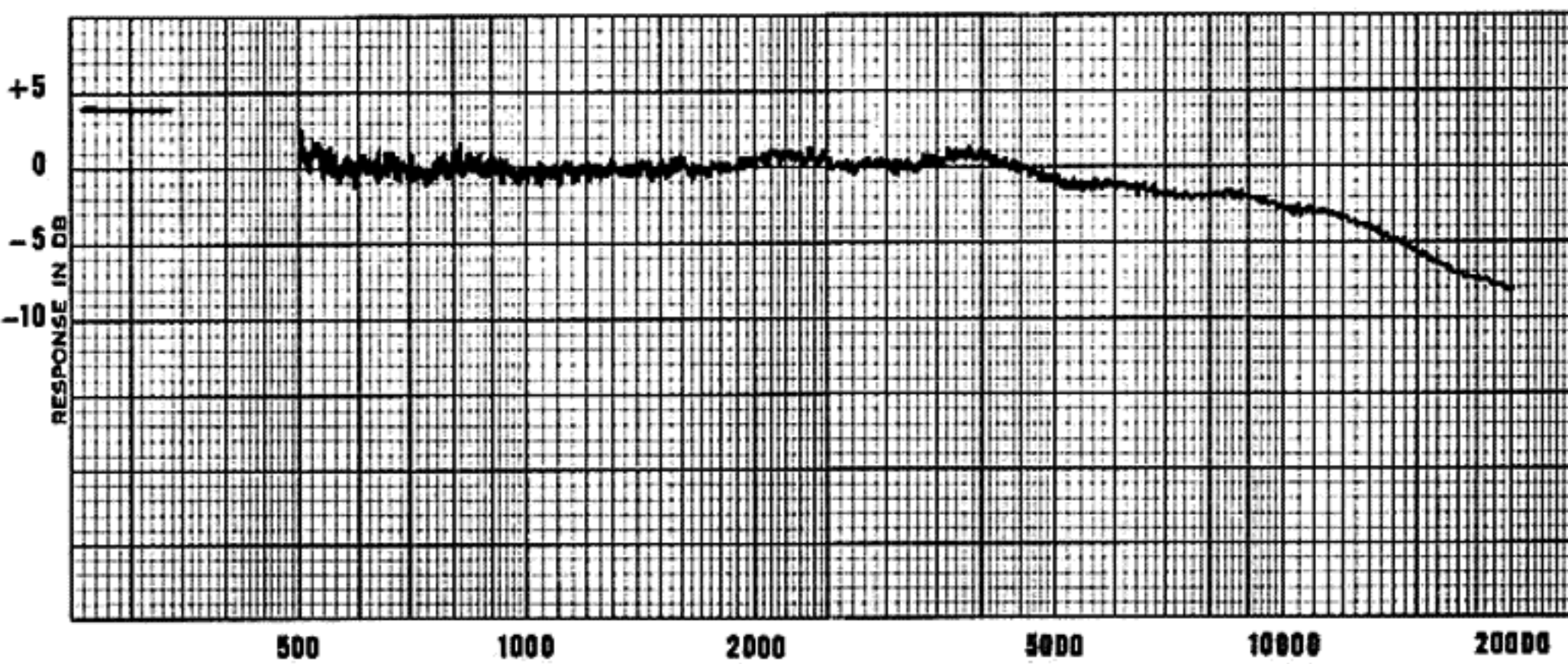
**Switch Position 2**



**Switch Position 5**

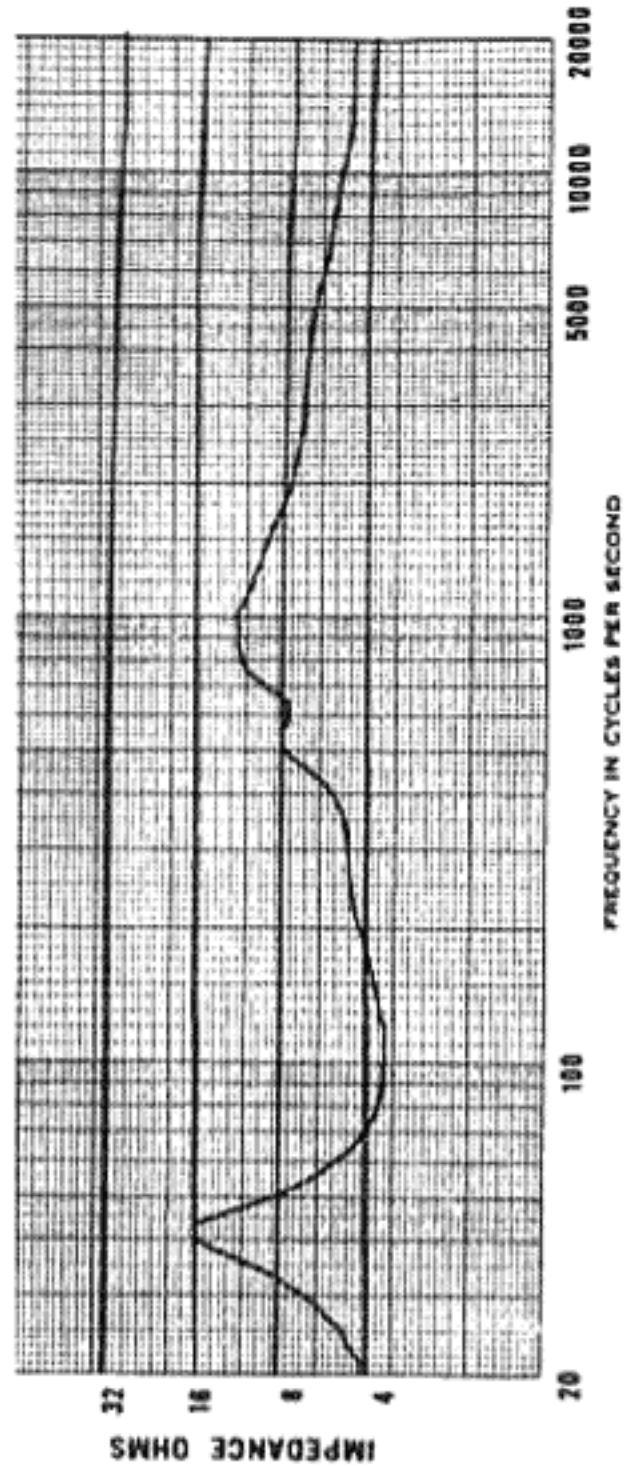


**Switch Position 3**

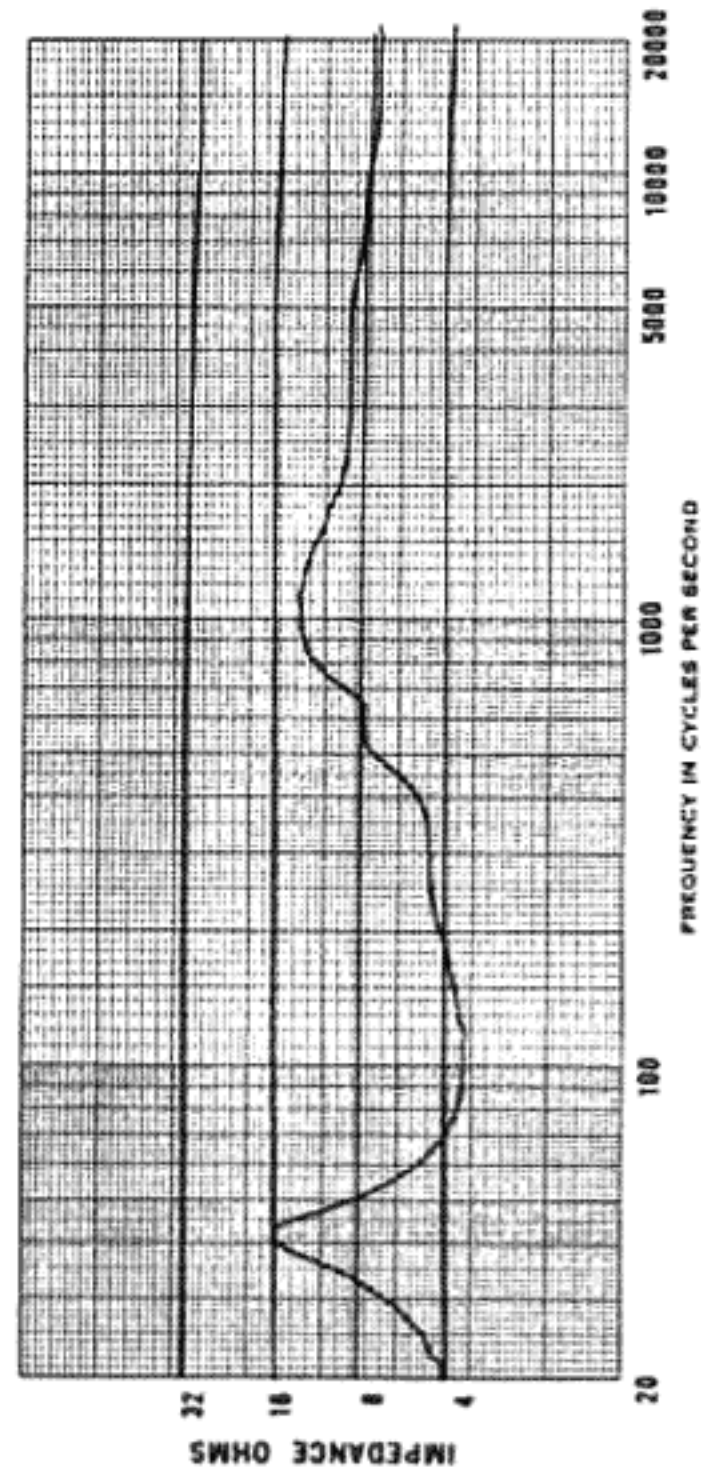


**Switch Position 6**

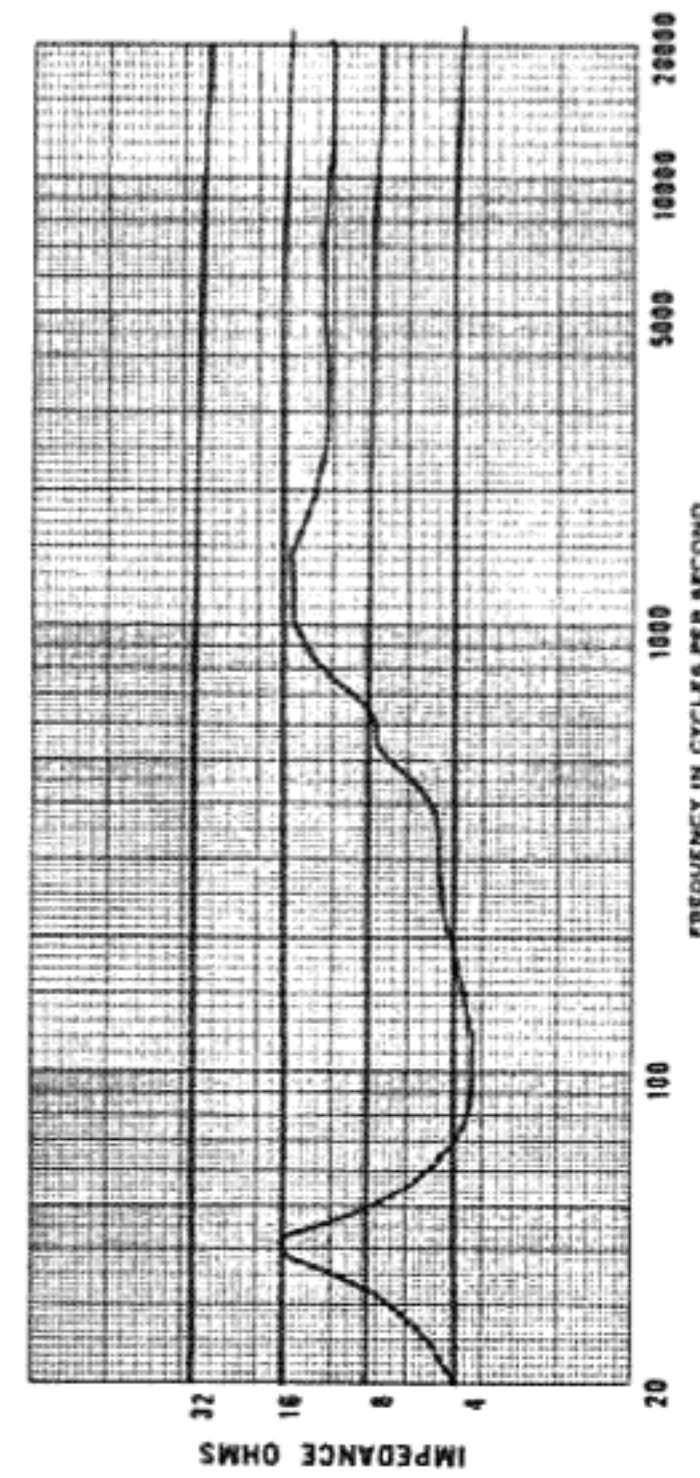




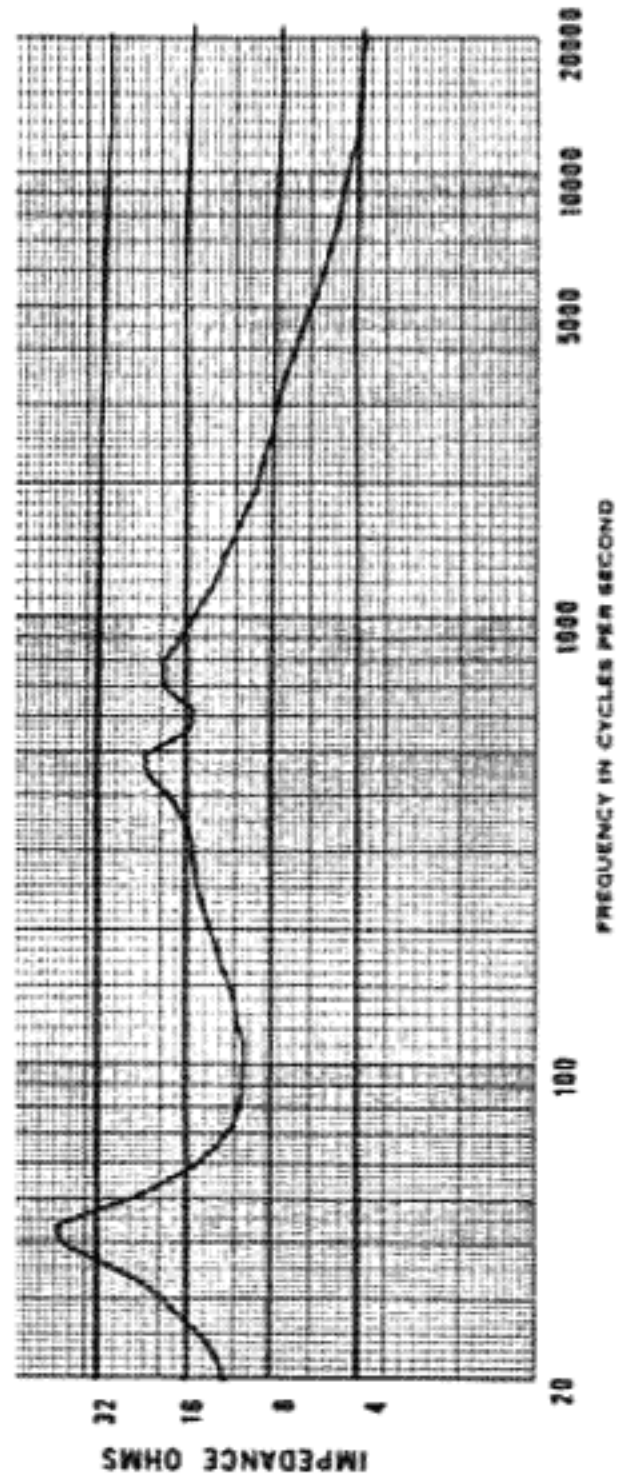
Switch Position 4



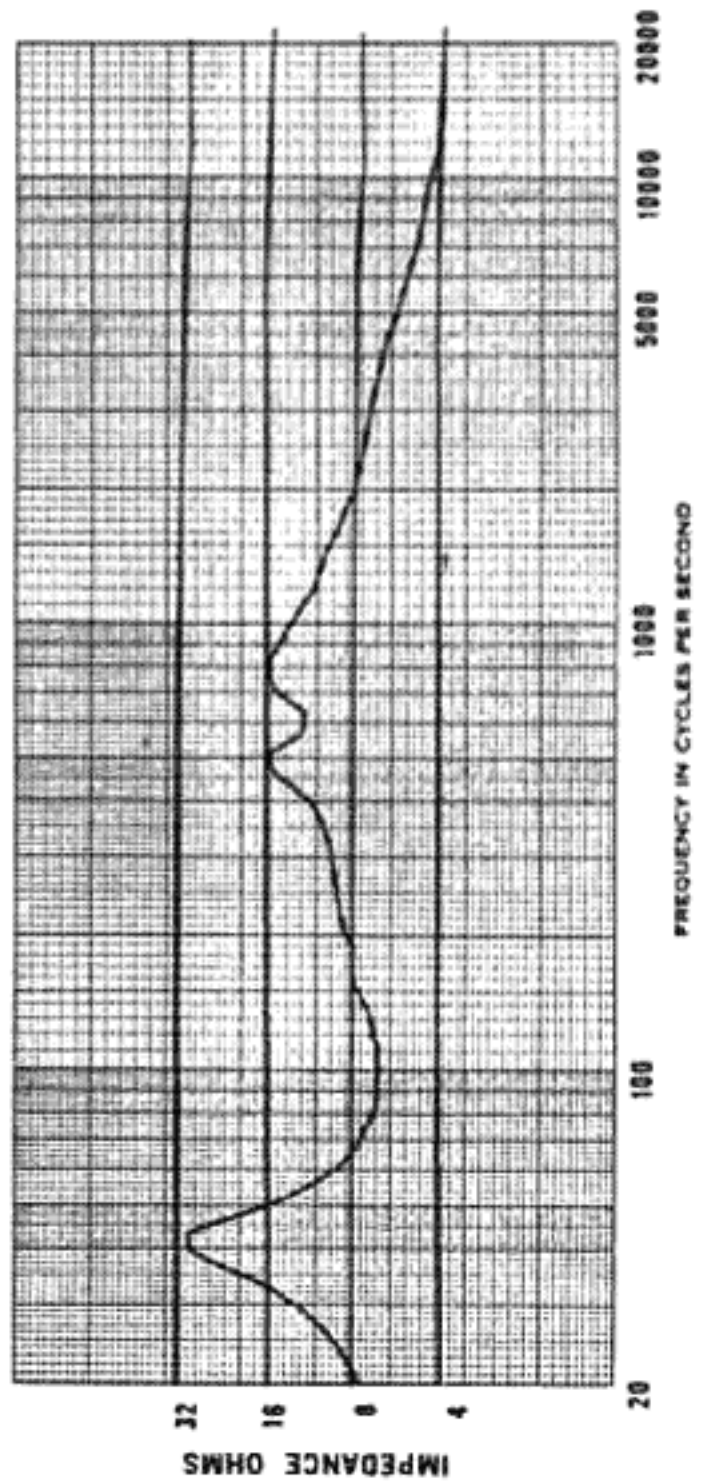
Switch Position 5



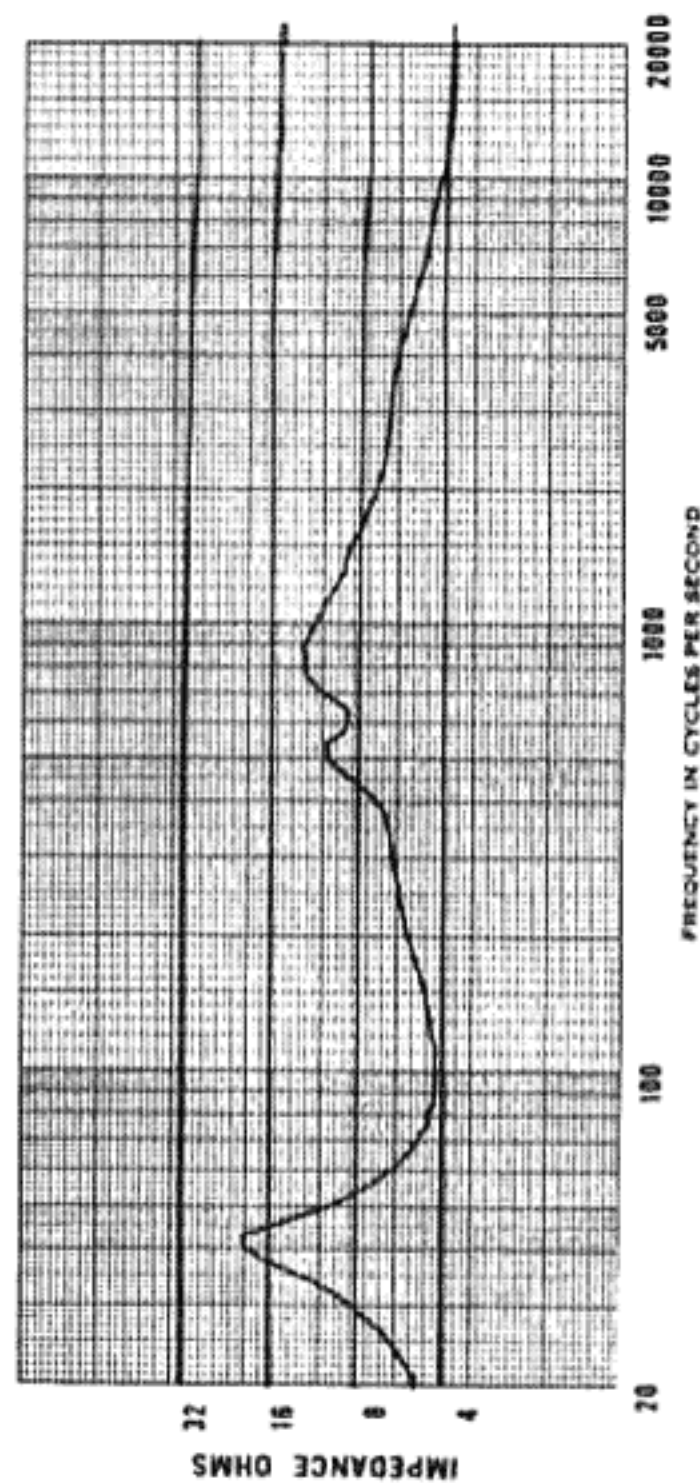
Switch Position 6



Switch Position 1



Switch Position 2



Switch Position 3

Figure 3: Anechoic Response of Individual Drivers

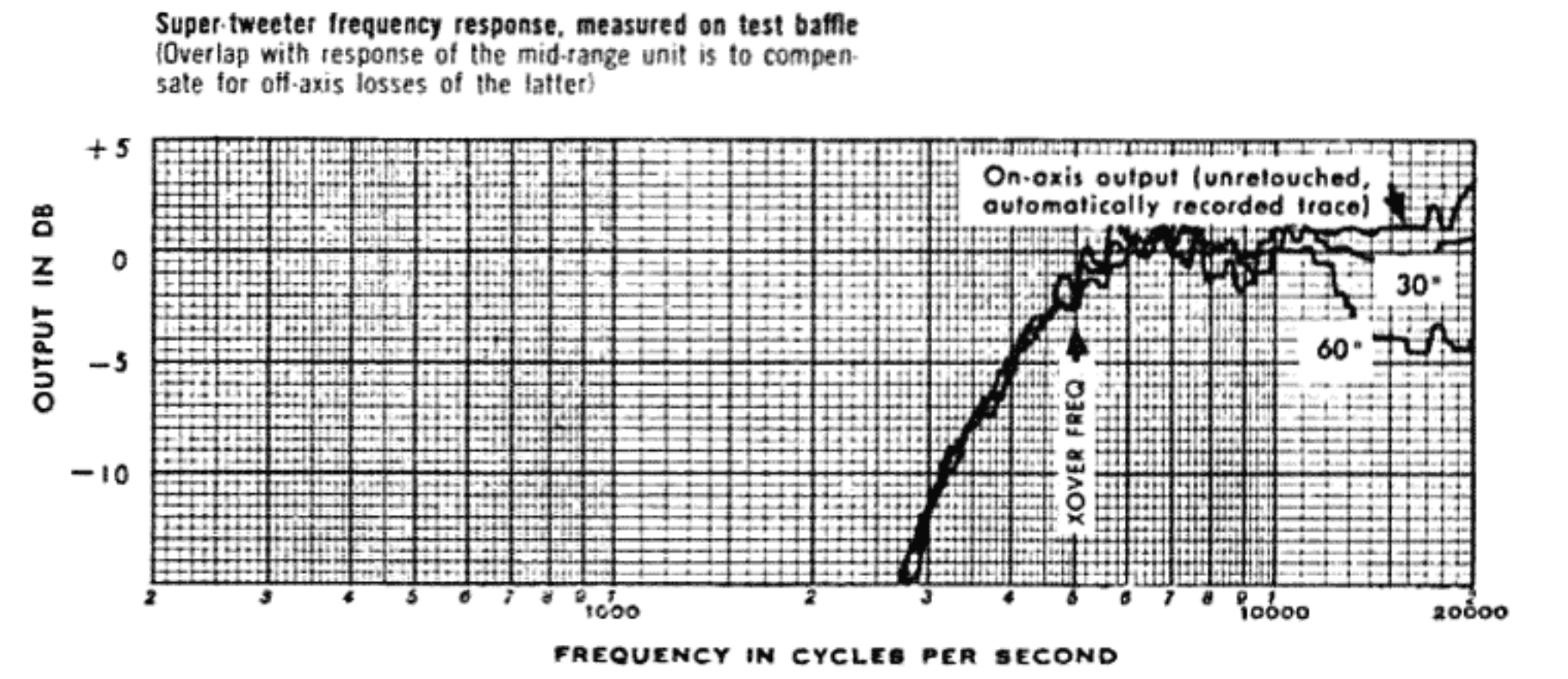
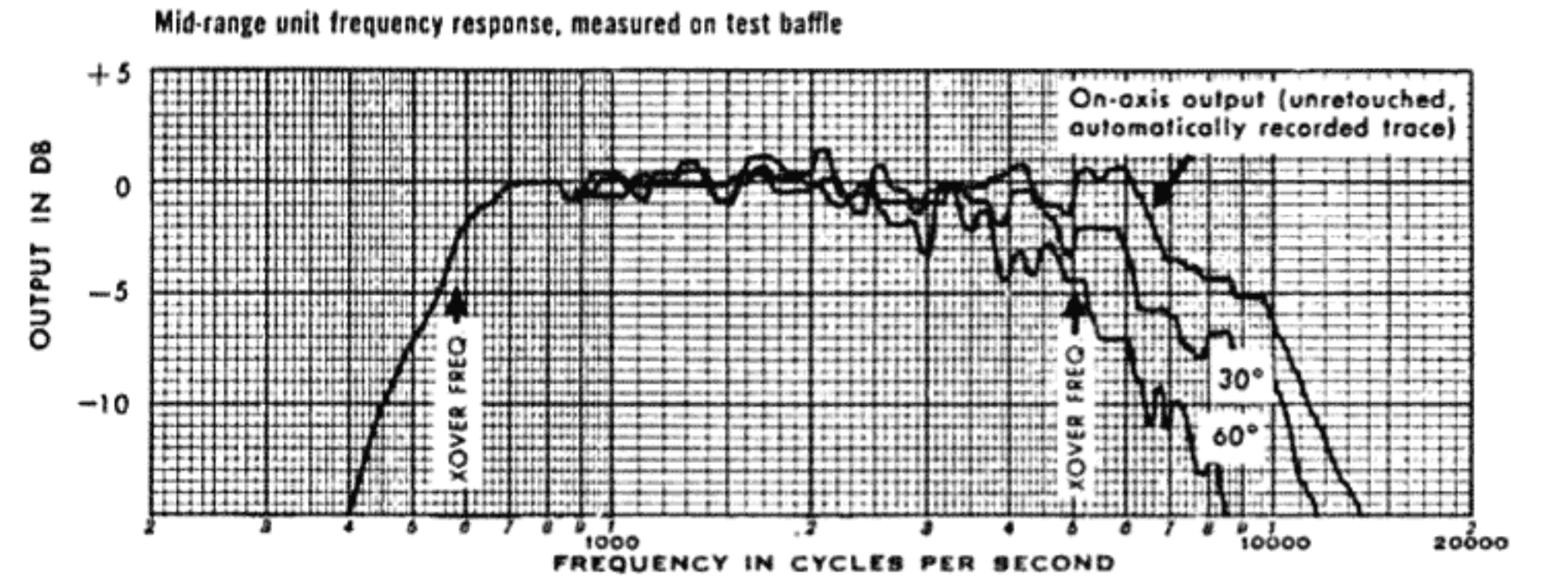
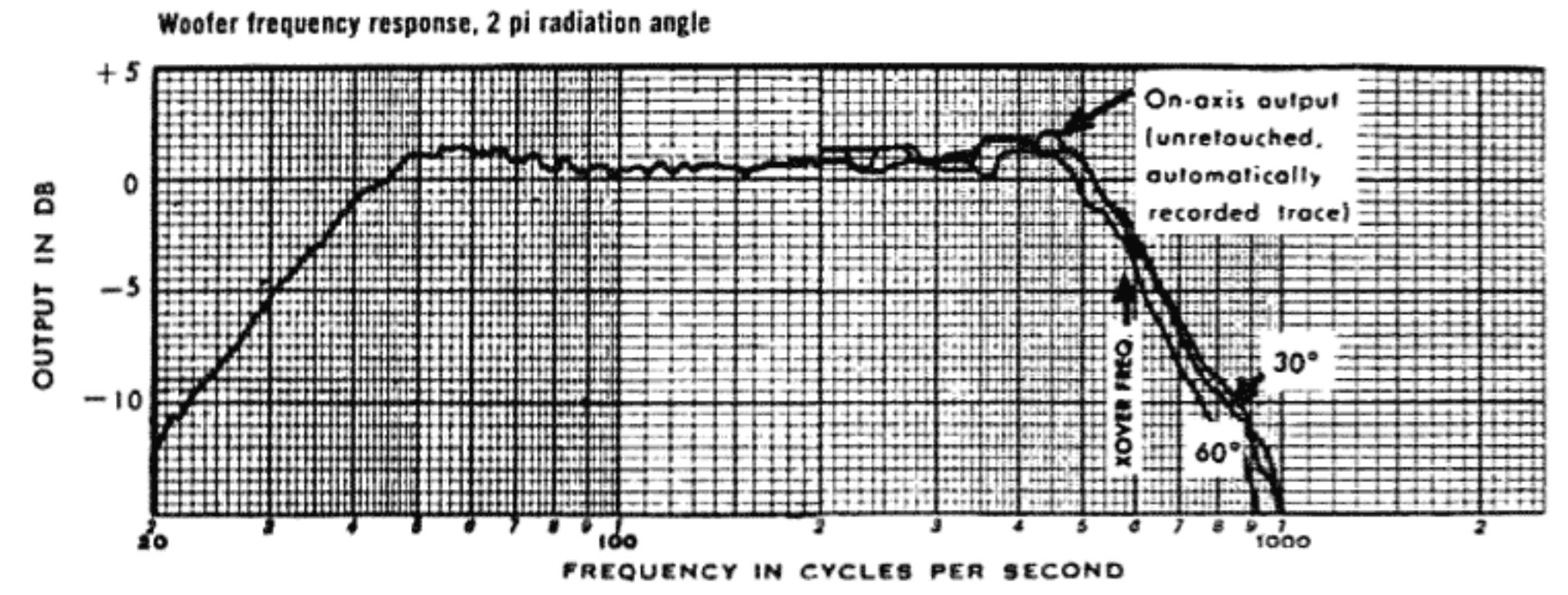
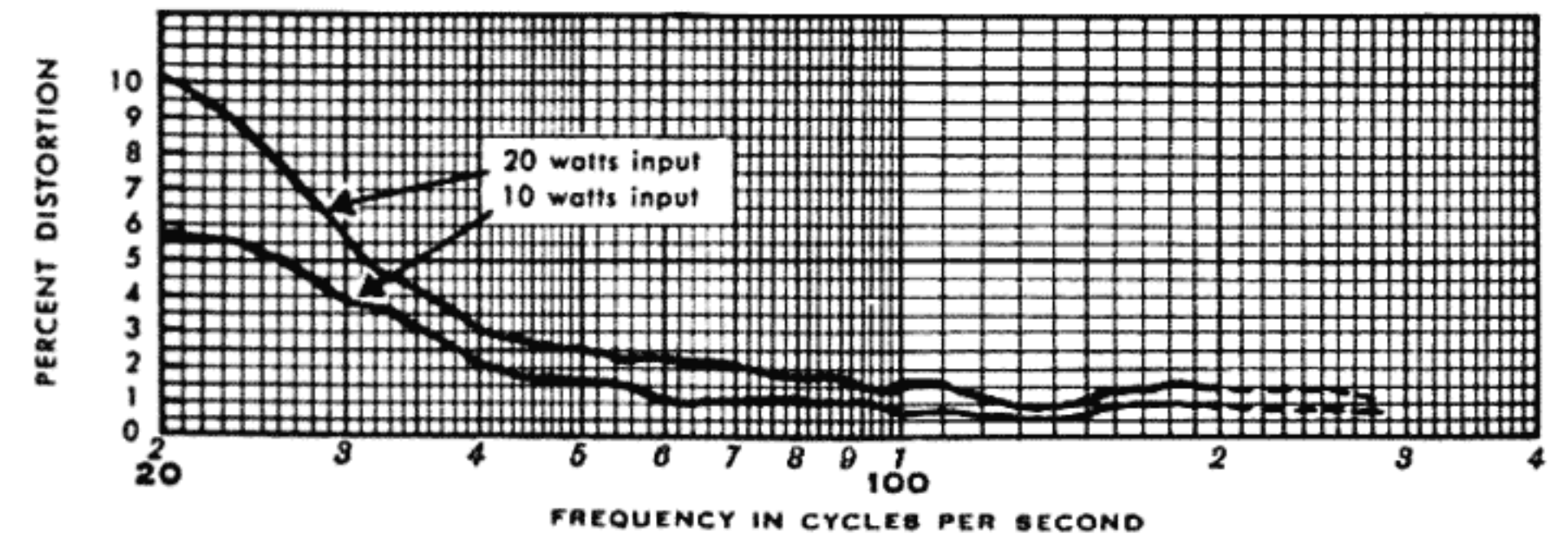
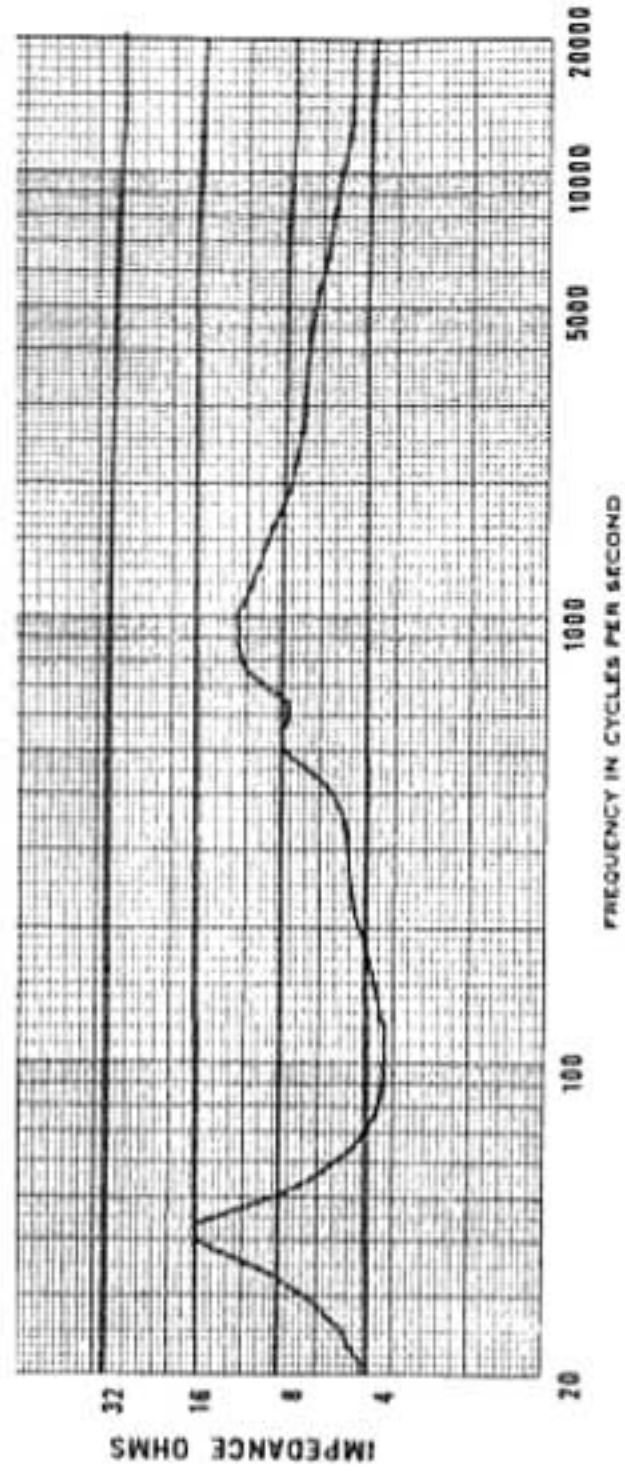


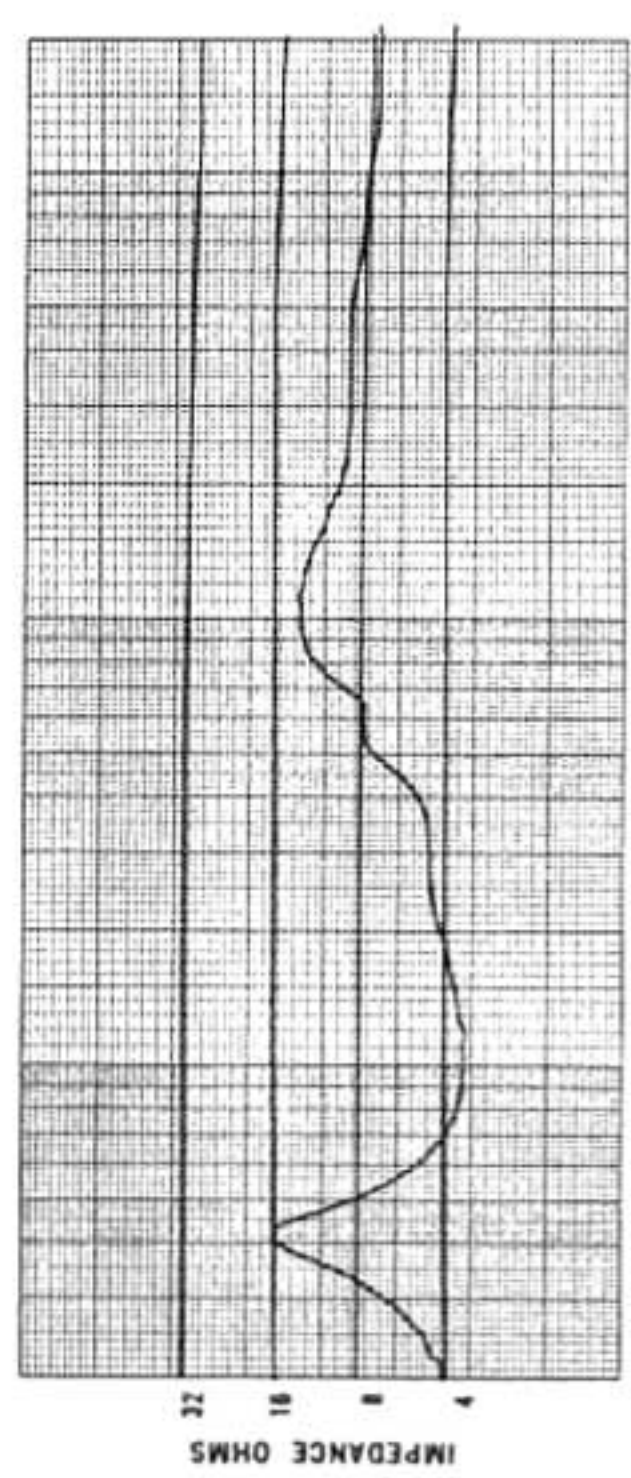
Figure 4: Low-Frequency Distortion



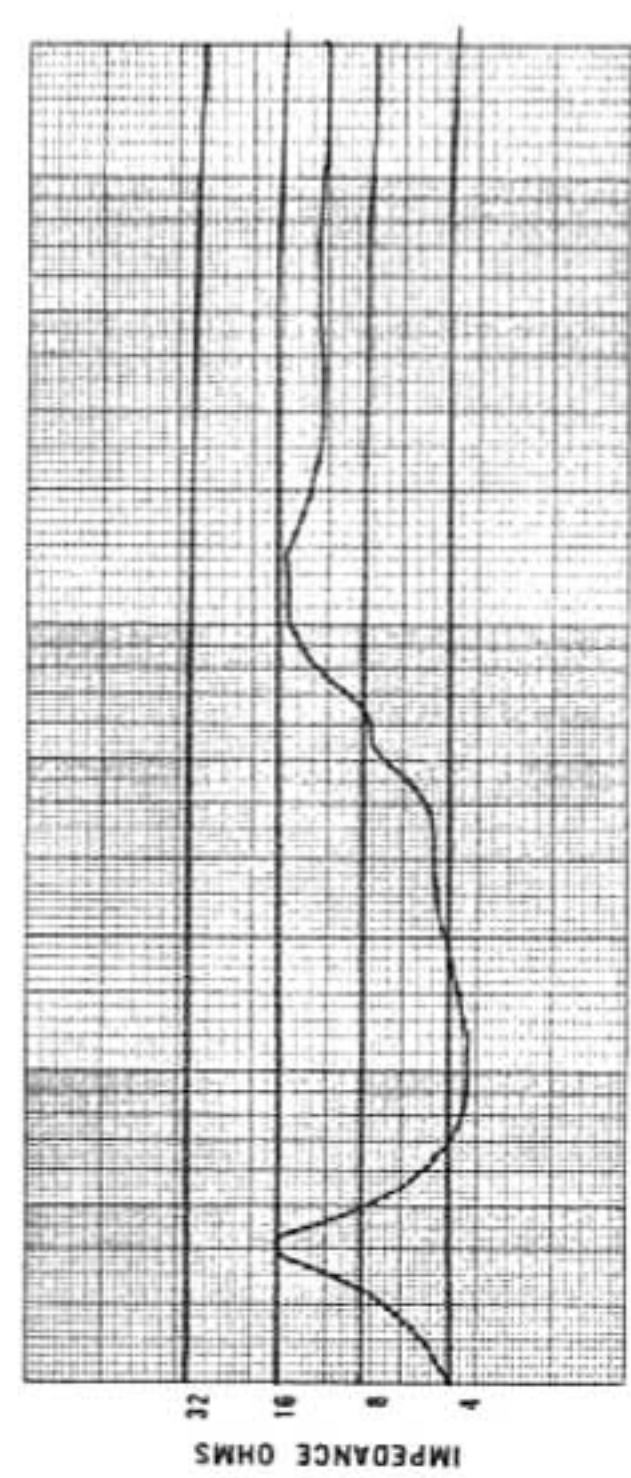




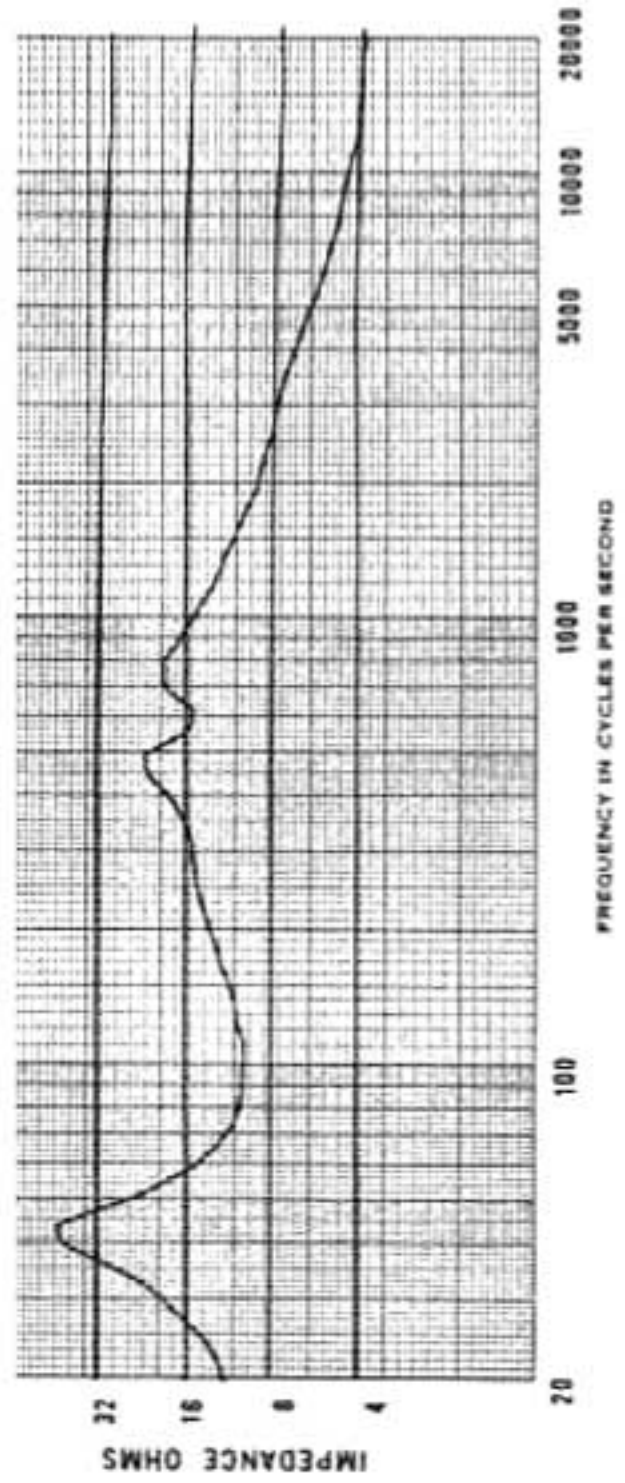
Switch Position 4



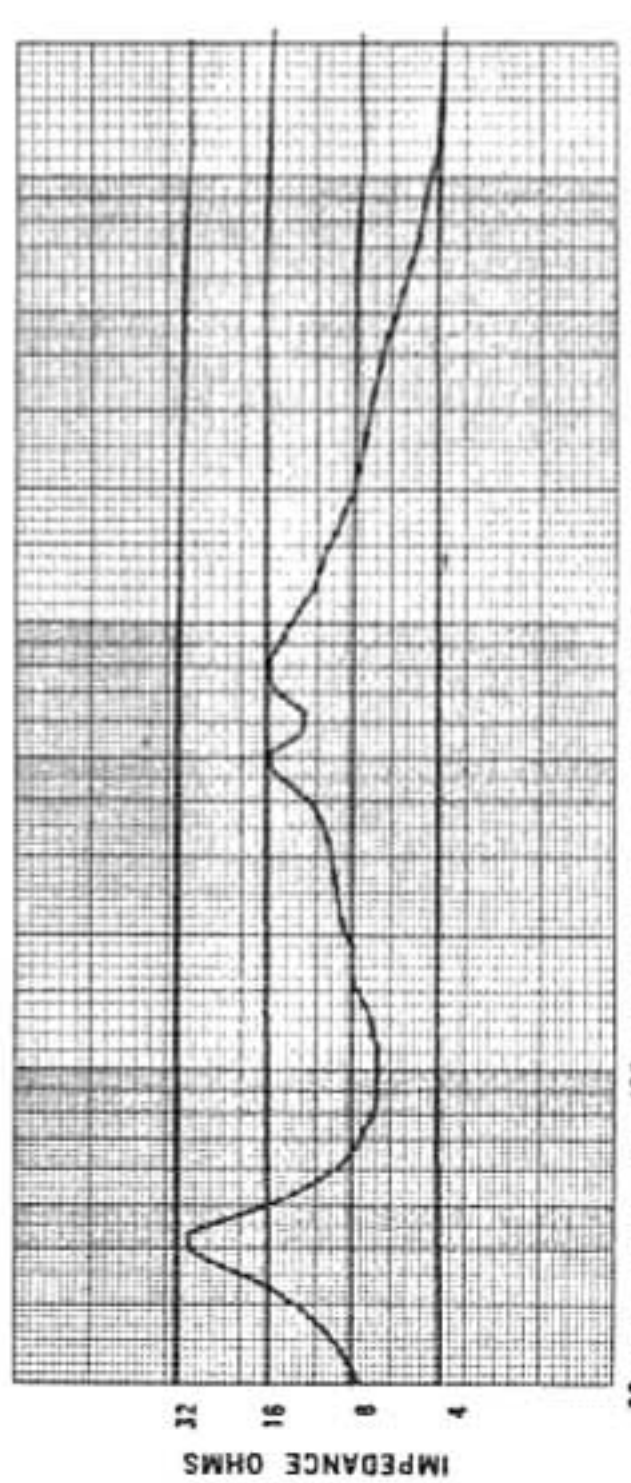
Switch Position 5



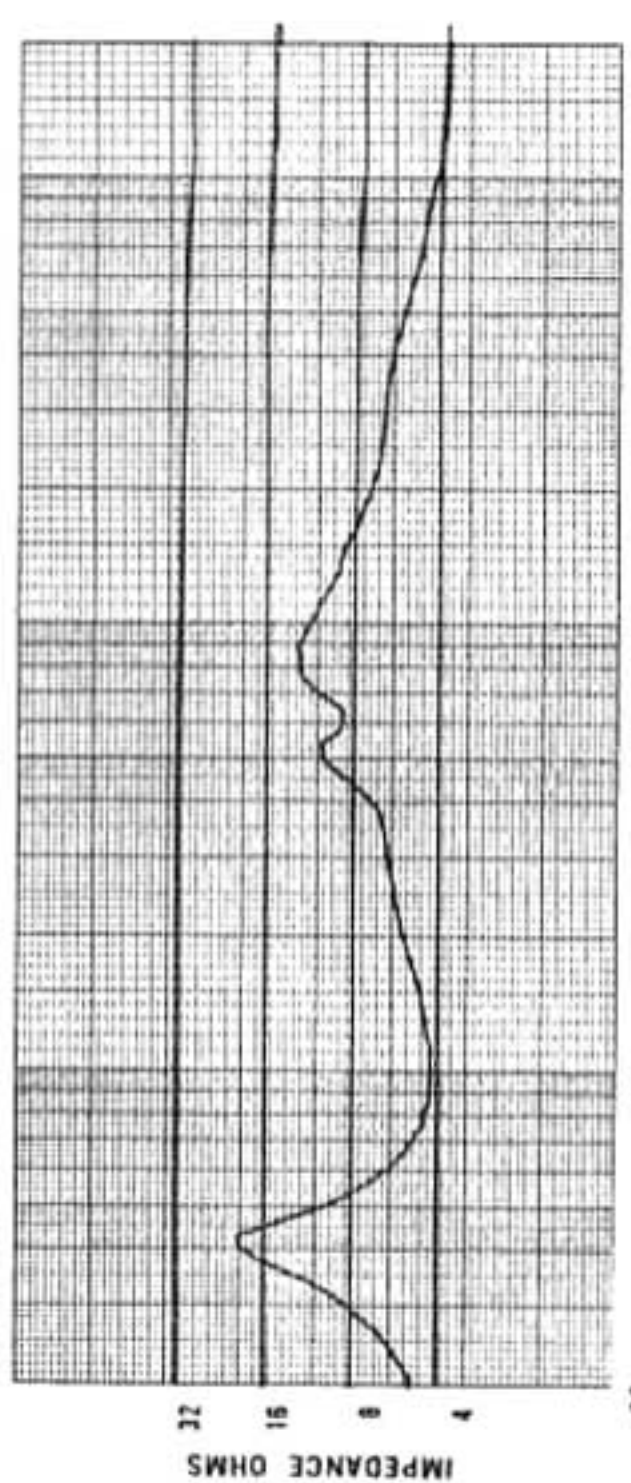
Switch Position 6



Switch Position 1



Switch Position 2



Switch Position 3

Figure 3: Anechoic Response of Individual Drivers

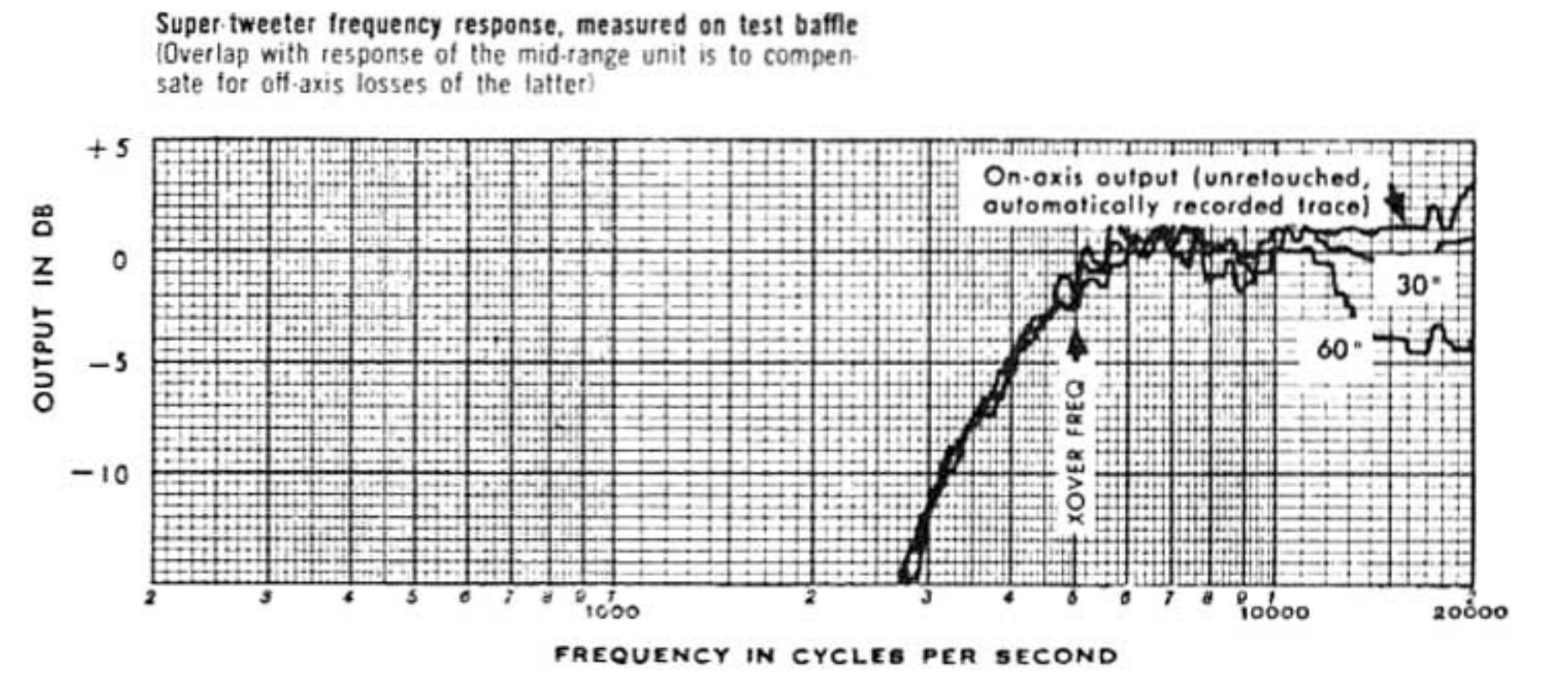
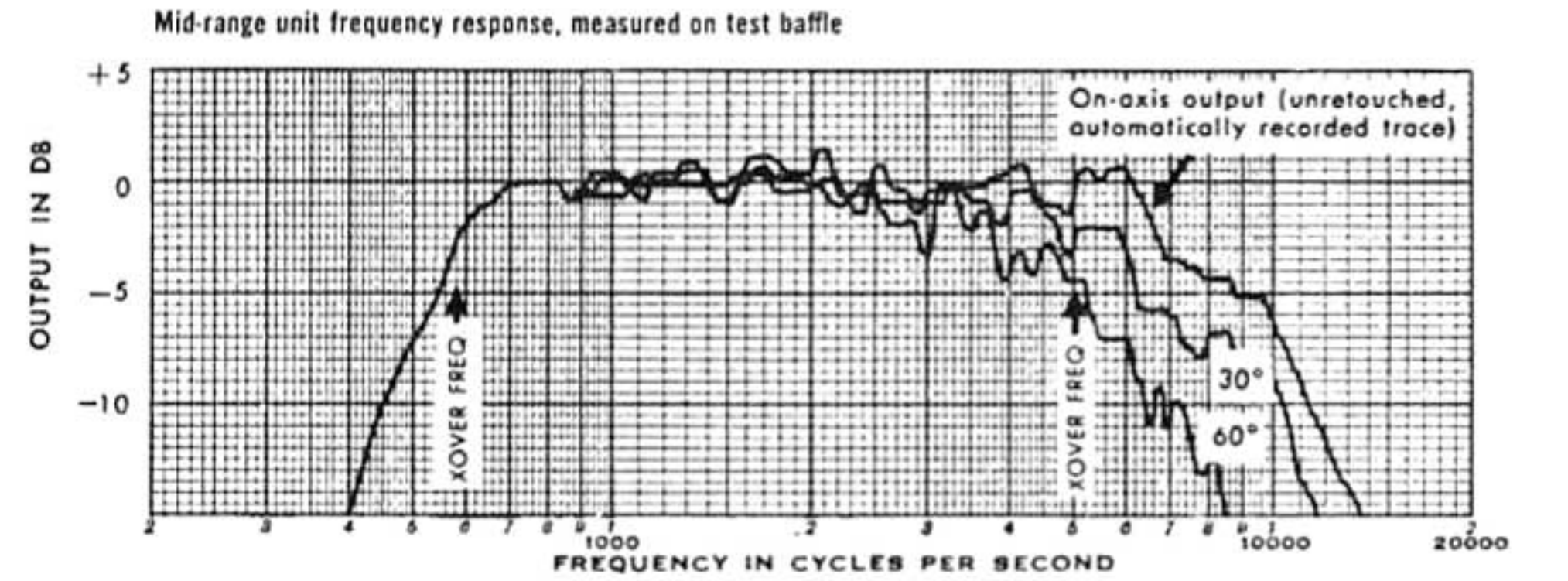
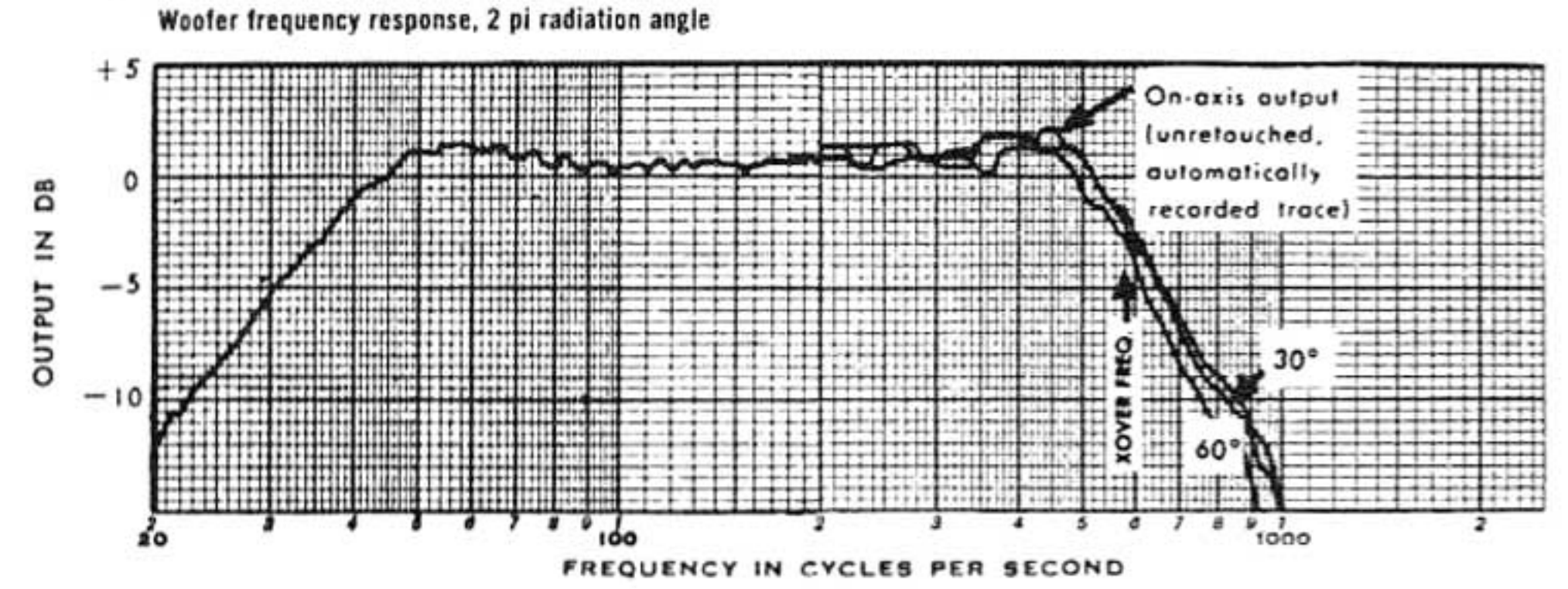
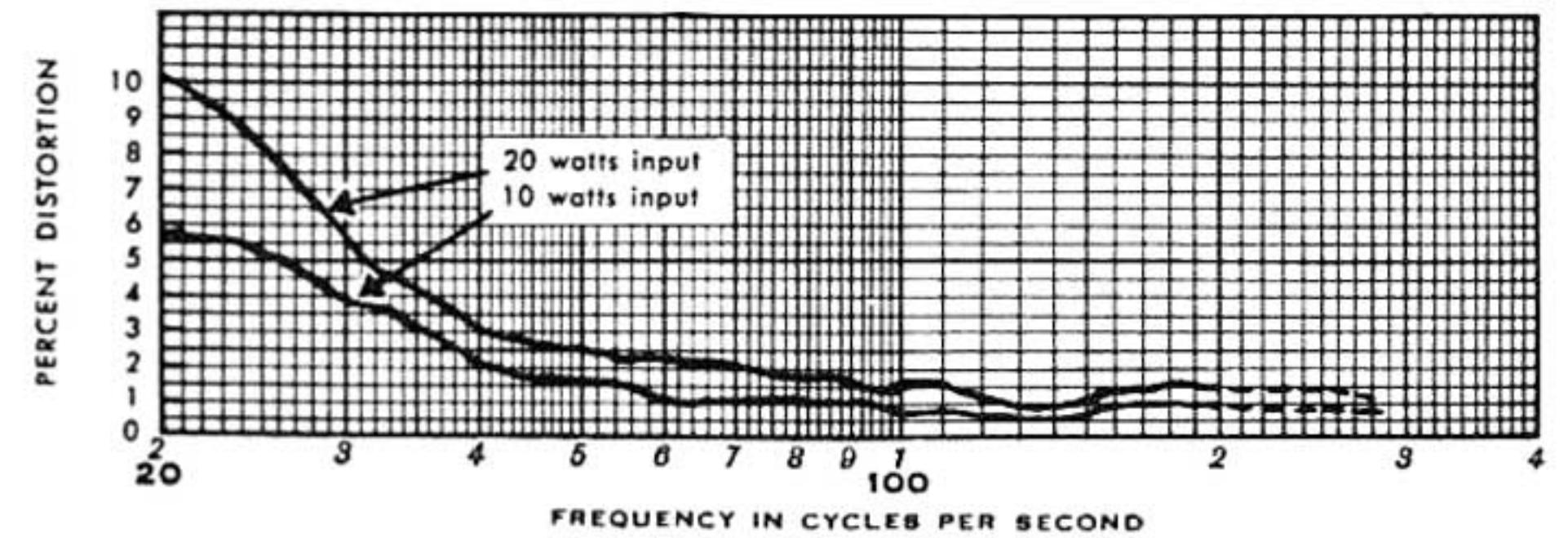


Figure 4: Low-Frequency Distortion





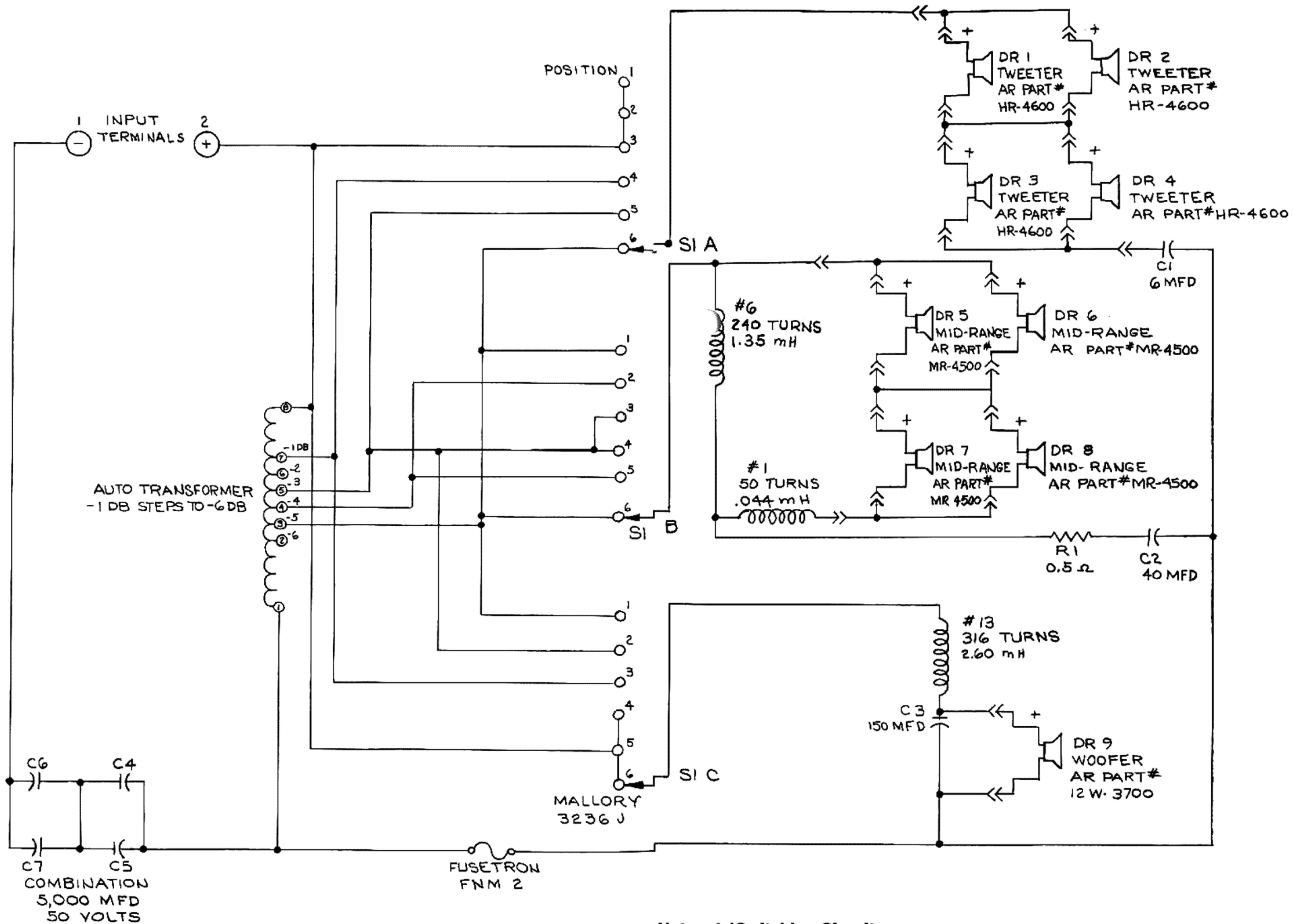


Figure 5: AR-LST Crossover Network/Switching Circuit



## **The AR Guarantee**

The workmanship and performance in normal use of the AR Laboratory Standard Transducer are guaranteed for five years from the date of purchase. The guarantee covers parts, repair labor, and freight costs to and from our factory or nearest authorized service station. New packaging, if needed, is also free. There is no service charge, nor is anyone authorized to charge for in-guarantee service. The phrase "normal use" does not include power input sufficient to cause thermal damage to the speaker voice coils.

## **In Case of Difficulty**

If you should determine that a speaker system is defective, *write to us directly*, describing the trouble symptoms and giving any other information that you think might be important. This may help us to suggest procedures that will expedite the repair and prevent unnecessary inconvenience to you. At the same time,

1. Give us the serial number of the unit and state the symptoms concisely.
2. Let us know if you have kept all cardboard parts of the original shipping carton or if you need a new one. The AR-LST is very heavy for its size and must be shipped in a carton designed for it; otherwise damage to the cabinet during shipment is likely.

Please fill out and return the guarantee card promptly.